

450 mm / 650 mm / 1000 mm 階規
CHECK MASTER



標準規格 Check Master			
型號 Model No.	CW-450L	CW-650L	CW-1000L
精確度 Accuracy	≤ 2 um	≤ 3 um	≤ 6 um
量測範圍 Range	0~450 mm	0~650 mm	0~1000 mm
環境溫度 Temperature	T = 20 ± 1°C		

垂直儀
VERTICAL TESTER



型號 Model No.	V-300	V-600
量測範圍 Range	0~300 mm	0~600 mm
精確度 Accuracy		
真直度 Straightness	≤ 3 um	≤ 5 um
垂直度 Squares	≤ 3 um	≤ 5 um
操作方式 Operation	手動 Manual	手動 Manual
重量 Weight	8Kg	10Kg
環境溫度 Temperature	T=20 - 23°C	T=20 - 23°C



建緯精密科技股份有限公司
CHIEN WEI PRECISE TECHNOLOGY CO., LTD.

台灣高雄總公司地址：高雄市鳳山區 83041 鎮北里鎮北北巷 20-16 號
HEADQUARTERS

No. 20-16, Chen Pei N. Lane,

Fengshan District, Kaohsiung City 83041, Taiwan.

TEL : 886-7-7313911 FAX : 886-7-7314976

E-Mail : info@chienwei.com.tw http://www.chienwei.com/

桃園辦事處地址：桃園縣八德市大明街 3 號

TEL : 886-3-3617817 FAX : 886-3-3618603

台中辦事處地址：台中市北屯區軍福十八路 13 號

TEL : 886-4-24373526 FAX : 886-4-24392589

昆山長豐精密儀器有限公司

KUNSHAN CHANGFENG PRECISE INSTRUMENTS CO., LTD.

江蘇省昆山市張浦鎮大市中吉山路 12 號

TEL : 86-512-57258001 FAX : 0512-57258006

E-Mail : kschangfeng@163.com



※本公司保留對此型錄做修改之權利，修改時恕不另行通知。(2016-7)
※Chien Wei reserves the right to change specifications without notice.



建緯精密科技股份有限公司
CHIEN WEI PRECISE TECHNOLOGY CO.,LTD.

CNC Vertical Grinding Machine
CVG Series Vertical Grinding Machine



高精度CNC立式磨床

高精度CNC立式磨床

CNC Vertical Grinding Machine

CVG 4T / 8CT / 12CT

- 特點：(1) C軸採用液靜壓轉盤，研磨真圓度可達到 1 μ m 左右
(2) X.Z軸採用HEIDENHAIN光學尺，解析度 0.05 μ m
(3) X.Z軸最小設定單位0.0001 mm
(4) 自動刀具更換裝置ATC，4T刀把型式：BT40、8CT / 12CT刀把型式：BT50
(5) 自動修砂及自動補償功能

High-Precision Vertical Grinding Machine-CNC

CVG 4T / 8CT / 12CT

- Feature : 1. Hydrostatic rotary table adopted in C axis ; Roundness : approximate 1 μ m
2. HEIDENHAIN linear encoder equipped in X and Y axis ; resolution : 0.05 μ m
3. Minimum setting unit 0.0001 mm in X and Z axis
4. Automatic tool changer ATC ; 4T spindle taper : BT40 ; 8CT / 12CT spindle taper : BT50
5. Feature auto-dressing and auto-compensation



CVG-4T

CVG-8CT



CVG-12CT

8CT/12CT 加工試樣與量測 Workpiece Trial & Measurement

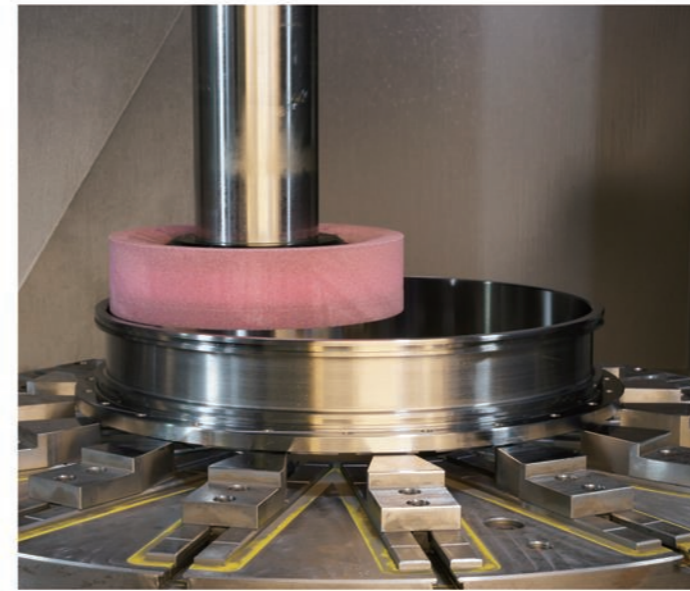

立車剎車環內外研磨
Brake Ring of Vertical Lathe internal / external grinding

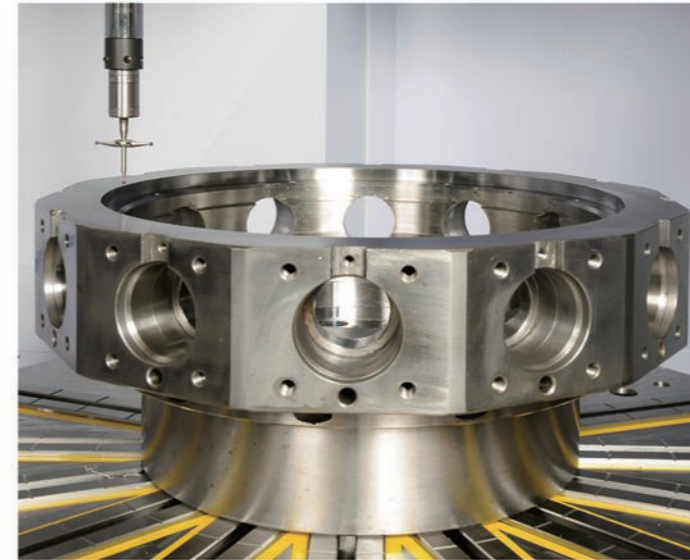

自動線上量測
Automatic online measurement

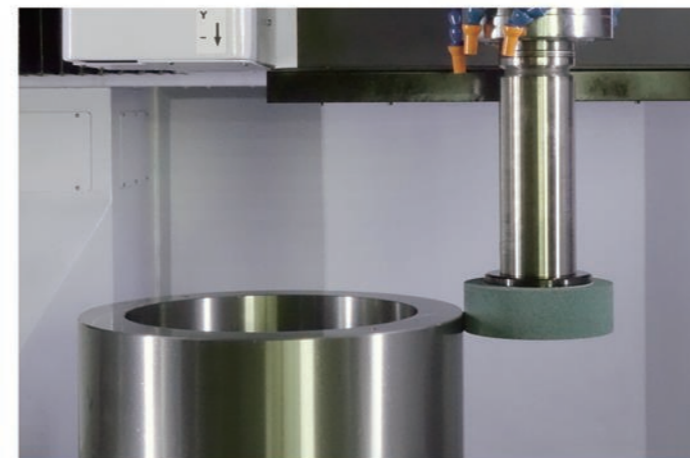

外圈研磨
Exterior circle grinding



油霧回收器及冷卻系統
Mist collector and cooling system



液靜壓幫浦
Hydrostatic pump

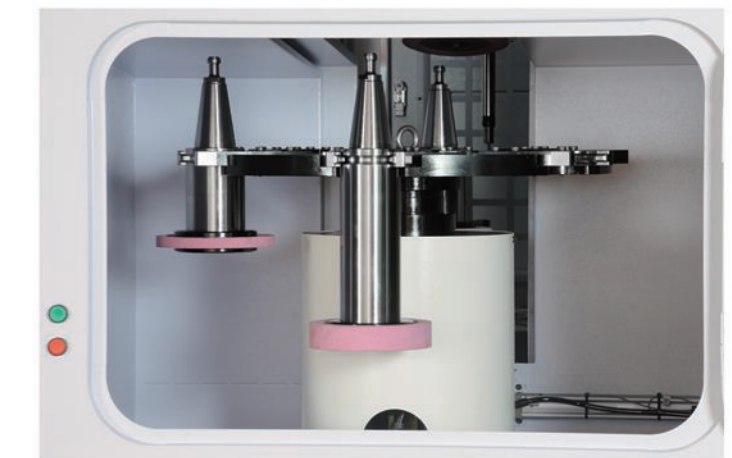

研磨砂輪放置刀庫
Tool magazine

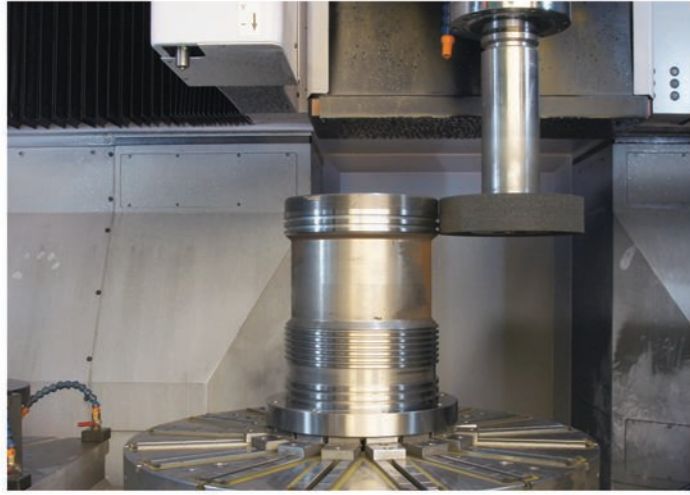

主軸套件
Spindle parts grinding

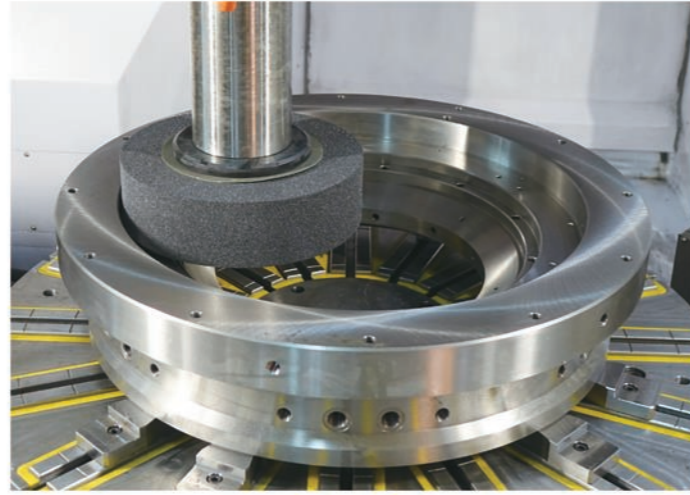

套環配件
Collar grinding



針齒殼零件
Parts of pin wheel housing

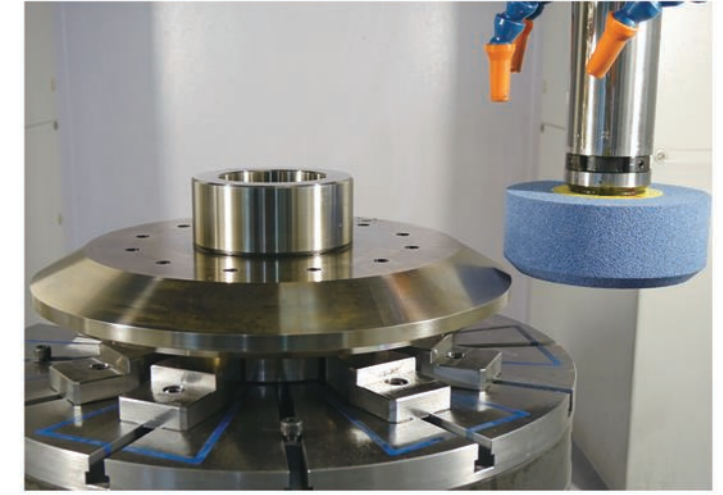

液靜壓零件
Parts of hydrostatic system

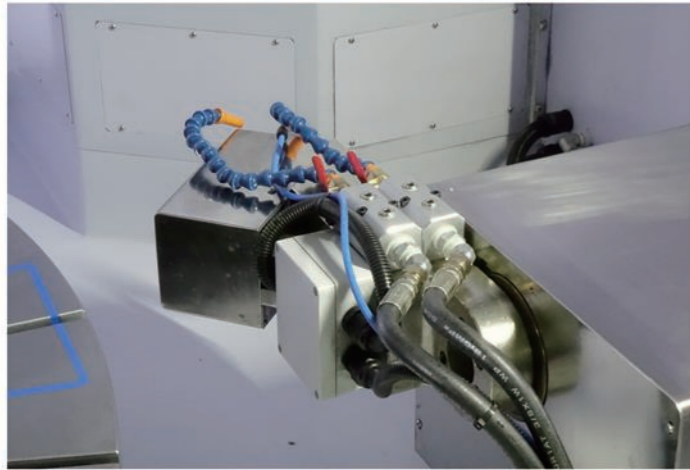

修砂器90度起降
90 degree rotation dresser

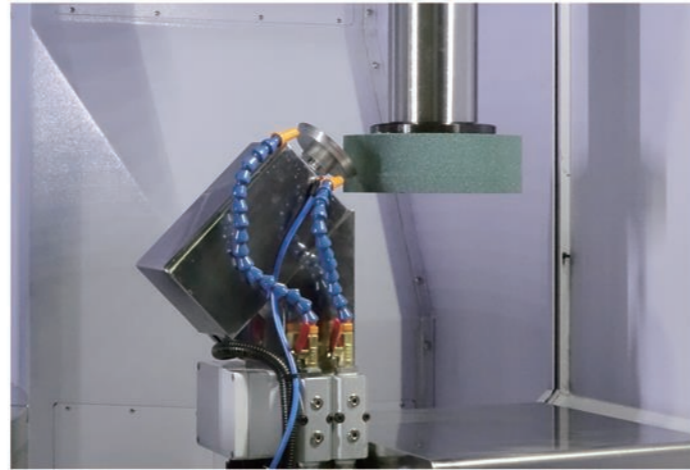

旋軸修砂器
Rotating dresser



齒輪箱套件
Gear box grinding



主軸外套加工
Spindle housing grinding

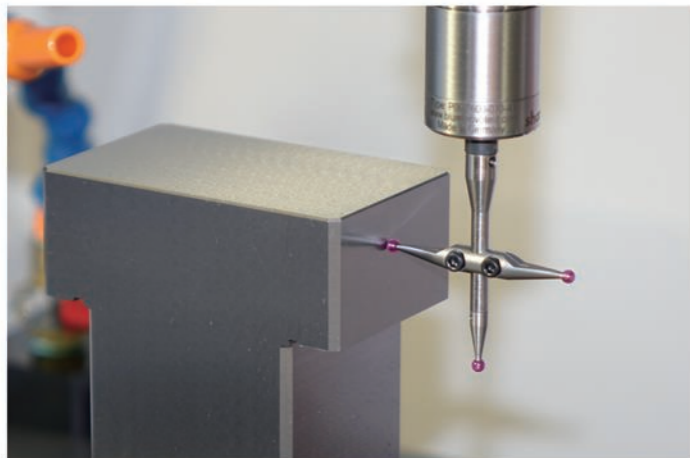

量測校正
Measurement calibration



端面研磨
Surface grinding

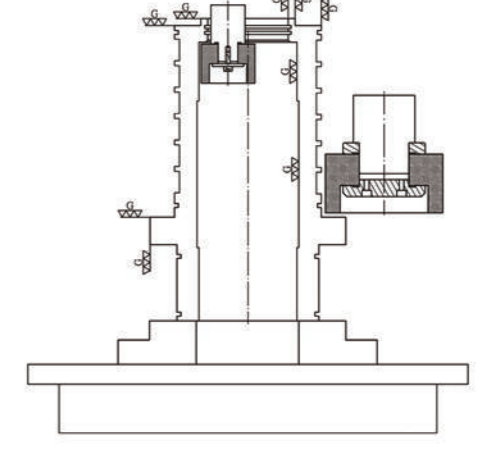
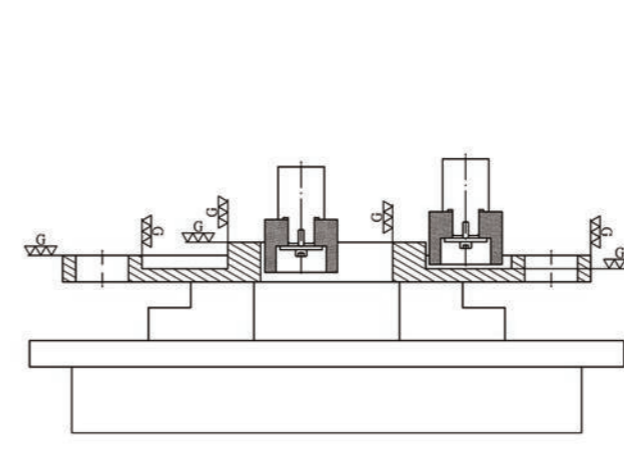

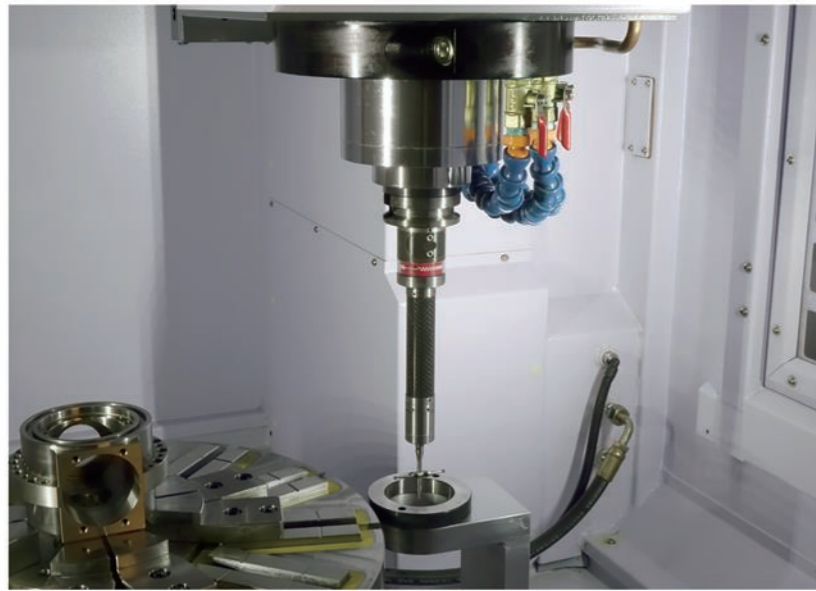

量測校正
Measurement calibration

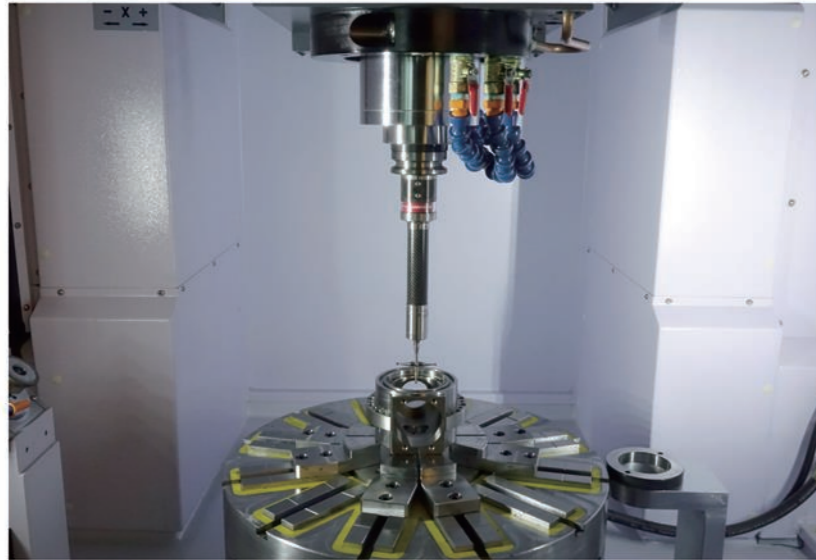

加工件量測
Workpiece measurement

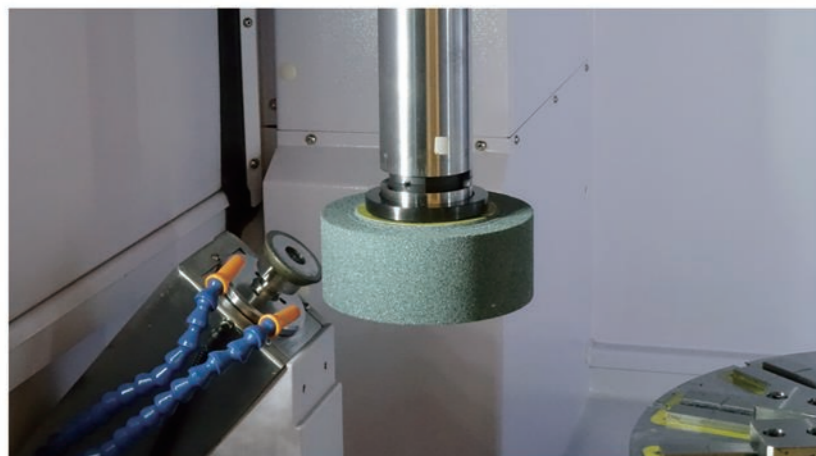

旋轉修砂，自動補償功能
Auto-dressing & Auto-compensation



油霧回收器及冷卻系統
Mist collector and cooling system



液靜壓幫浦
Hydrostatic pump



研磨砂輪放置刀庫
Tool magazine

項目	ITEM	UNIT	CVG-4T	CVG-8CT	CVG-12CT
電控系統	Electronic control system				
數值控制器	NC controller	unit	0i-MF	32iB	32iB
研磨能力	Capacity				
內徑研磨尺寸範圍	Range of internal grinding diameter	mm	∅50~∅400	∅50~∅800	∅50~∅1200
外徑研磨尺寸範圍	Range of external grinding diameter	mm	∅450	∅800	∅1200
內徑研磨最大長度(ID)	Internal grinding length (ID)	mm	ID < ∅150 : 225 ID > ∅150 : 325	ID < ∅250 : 325 ID > ∅250 : 500	ID < ∅250 : 325 ID > ∅250 : 500
外徑研磨最大長度	External grinding length	mm	325	500	500
工件最大旋徑	Swing of work spindle	mm	∅450	∅850	∅1250
工件安裝最高高度 (包括夾具)	Workpiece height (including fixtures)	mm	400	600	600
工件最大載重	Max. load on work table	kg	250	1500	2500
X 軸行程	X axis travel				
向右行程	Travel (from spindle center to right)	mm	300	1340(ATC 位置)	1670(ATC 位置)
向左行程	Travel (from spindle center to left)	mm	690 (ATC 位置)	400	600
移動速度	Travel speed	mm/min	0~24000	0~24000	0~24000
最小設定單位	Min. setting unit	mm	0.0001	0.0001	0.0001
Z 軸行程	Z axis travel				
上下行程	Travel	mm	400	650	650
移動速度	Travel speed	mm/min	0~24000	0~24000	0~24000
最小設定單位	Min. setting unit	mm	0.0001	0.0001	0.0001
砂輪軸	Wheel spindle				
刀把型式	Tool holder		HSKA63	HSKA100	HSKA100
砂輪軸轉速	Wheel spindle speed	rpm	0~20000	0~10000	0~10000
砂輪直徑	Wheel diameter	mm	∅45~∅150	∅45~∅250(Advance) /∅275(MAX)	∅45~∅250(Advance) /∅275(MAX)
主軸	Spindle				
工作台尺寸	Dimension of work table	mm	∅450	∅800	∅1200
旋轉速度	Spindle speed	rpm	20~400	10~200	5~100
自動刀具更換裝置(ATC)	Automatic tool changer (ATC)				
刀把型式	Tool holder		HSKA63	HSKA100	HSKA100
砂輪儲存容量	Wheel storage capacity	Tools	8	6	6
最大砂輪(直徑 X 長度)	Max. wheel (diameter x length)	∅×mm	∅150X250	∅275X350	∅275X350
最大砂輪重量	Max. wheel weight	kg	8	20	20
選刀方式	Tool selection		umbrella type	umbrella type	umbrella type
電動機	Motors				
砂輪軸馬達	Wheel drive motor	kw	11/15(內藏式)	15/18.5(內藏式)	15/18.5(內藏式)
主軸馬達	Spindle drive motor	kw	3.7/5.5	3.7/5.5	3.7/5.5
X 軸伺服馬達	X axis motor	kw	3	6	6
Z 軸伺服馬達	Z axis motor	kw	4	6	6
機器重量佔地及包裝	Machine weight, space and packing				
地面空間(長 X 寬)	Floor space	mm	3303x2106	4073x3450	4173x4067
機器高度	Machine height	mm	3050	3644	3659
變壓器	Power capacity	KVA	27.5	33	33
淨重	Net weight	kg	7000	16000	19000

標準配備:

1.主軸油冷卻系統 Spindle cooling system	2.X/Z 軸光學尺 X/Z axis linear scale	3.基礎螺柱及水平調整螺帽 Bolts and leveling blocks
4.自動潤滑系統 Auto lubricating system	5.操作及使用手冊 Users manual	6.吹氣裝置 Air spray
7.全罩式板金 Full splash guard	8.LED 工作燈(2 座) LED work lamp (2sets)	9.水槍裝置 Water blow
10.RS232/RJ45 介面 RS232/RJ45 port	11.空調式冷卻機(8CT/12CT) Air conditioner for electrical equipment	12.切削水過濾裝置(含水箱、磁鐵及紙帶過濾機、油溫冷卻機、幫浦) Cooling system, including water tank, magnetic & paper filter, pump
13.C 軸油壓單元(變頻馬達 2.6KW) Power unit (Hydrostatic rotary table)	11.空調式冷卻機(8CT/12CT) Air conditioner for electrical equipment	12.切削水過濾裝置(含水箱、磁鐵及紙帶過濾機、油溫冷卻機、幫浦) Cooling system, including water tank, magnetic & paper filter, pump
14.傘型刀庫(CVG-4T(8T)/CVG-8CT(6T) Tool kit	11.空調式冷卻機(8CT/12CT) Air conditioner for electrical equipment	12.切削水過濾裝置(含水箱、磁鐵及紙帶過濾機、油溫冷卻機、幫浦) Cooling system, including water tank, magnetic & paper filter, pump
14.傘型刀庫(CVG-4T(8T)/CVG-8CT(6T) Tool kit	15.工具箱 Tool box	16.MPG 手輪 MPG turning wheel
17.三色警示燈 Pilot lamp	18.永電磁盤 Permanent electromagnetic disc	19.主軸油霧潤滑系統 Spindle oil mist lubrication system
20.油霧回收裝置(0.2KW/4T,0.3KW/8CT) Oil mist collector		

☆ 本公司對產品規格、設計特性均不斷研究改進,對上述規格保有修改之權利,若有變更,恕不另行通知。

CVG-4T外觀尺寸圖 External Dimension

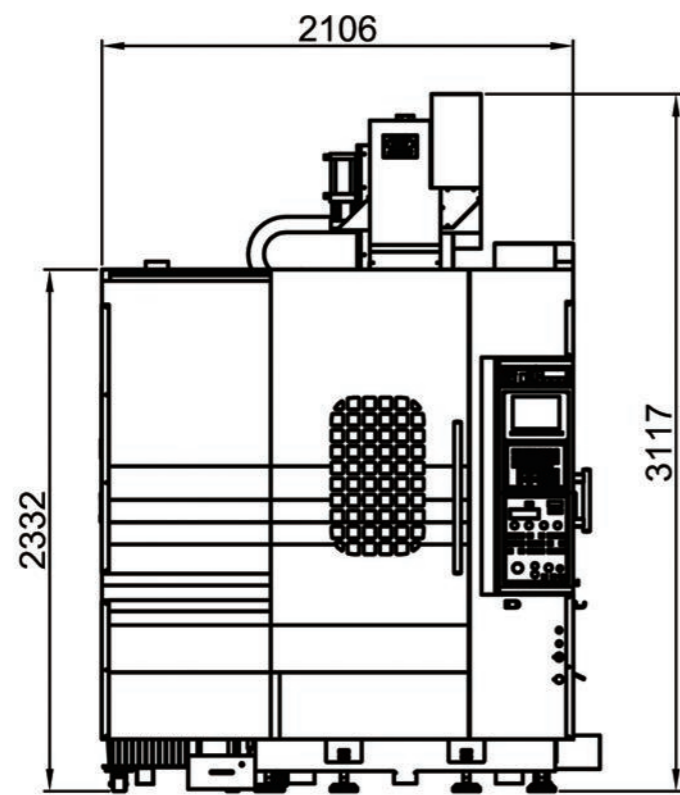
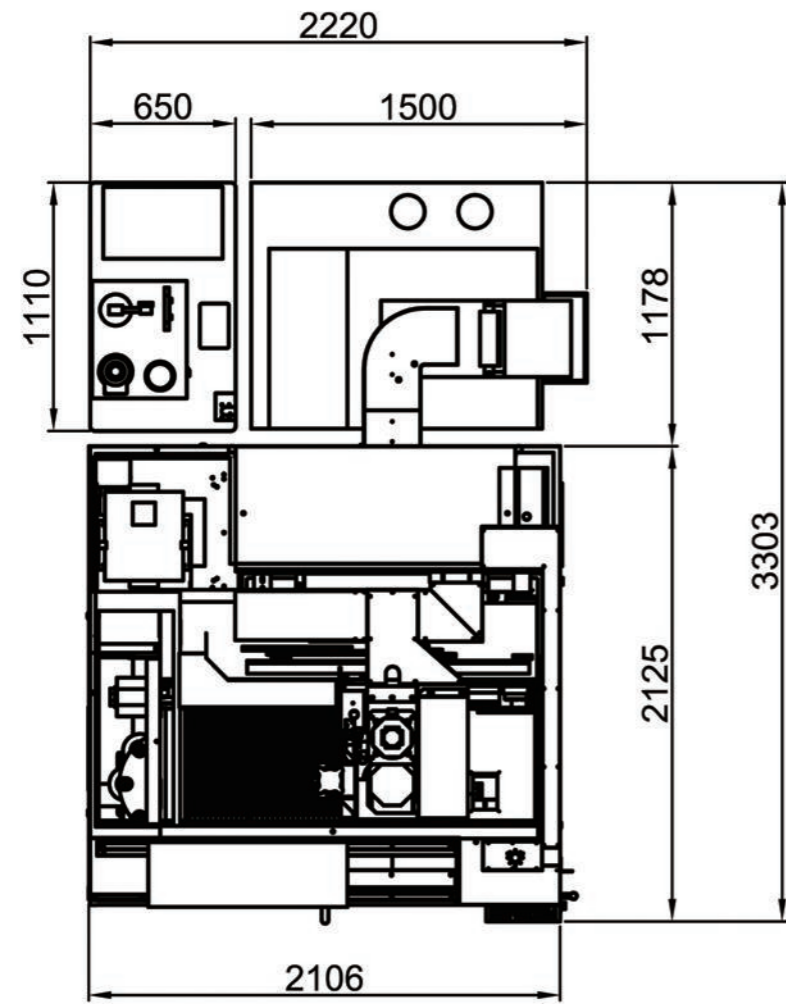

CVG-8CT外觀尺寸圖 External Dimension

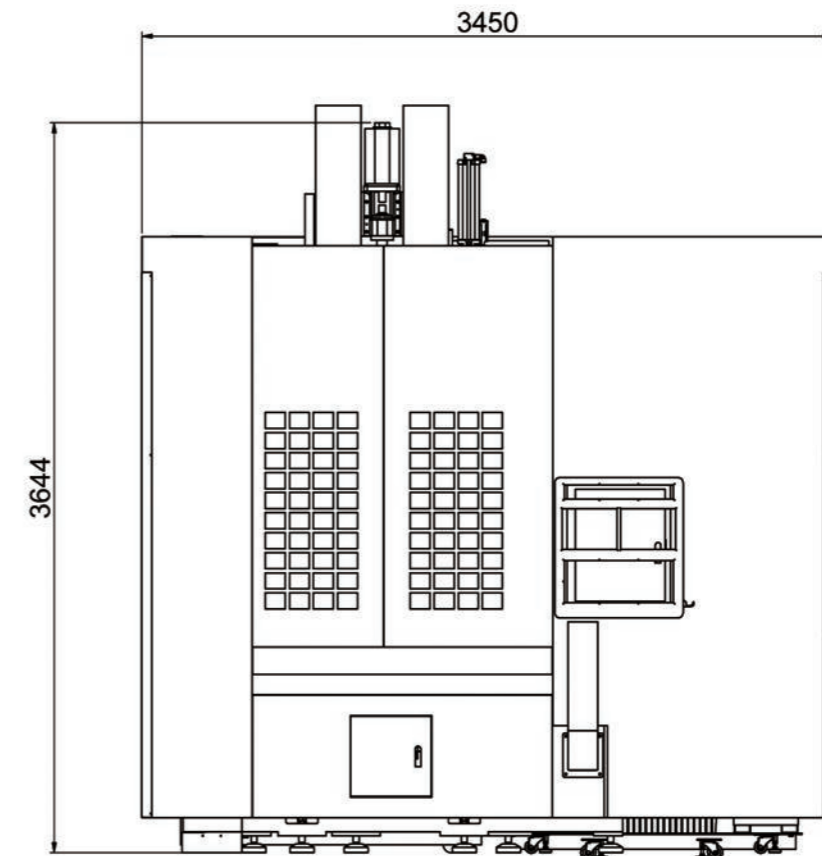
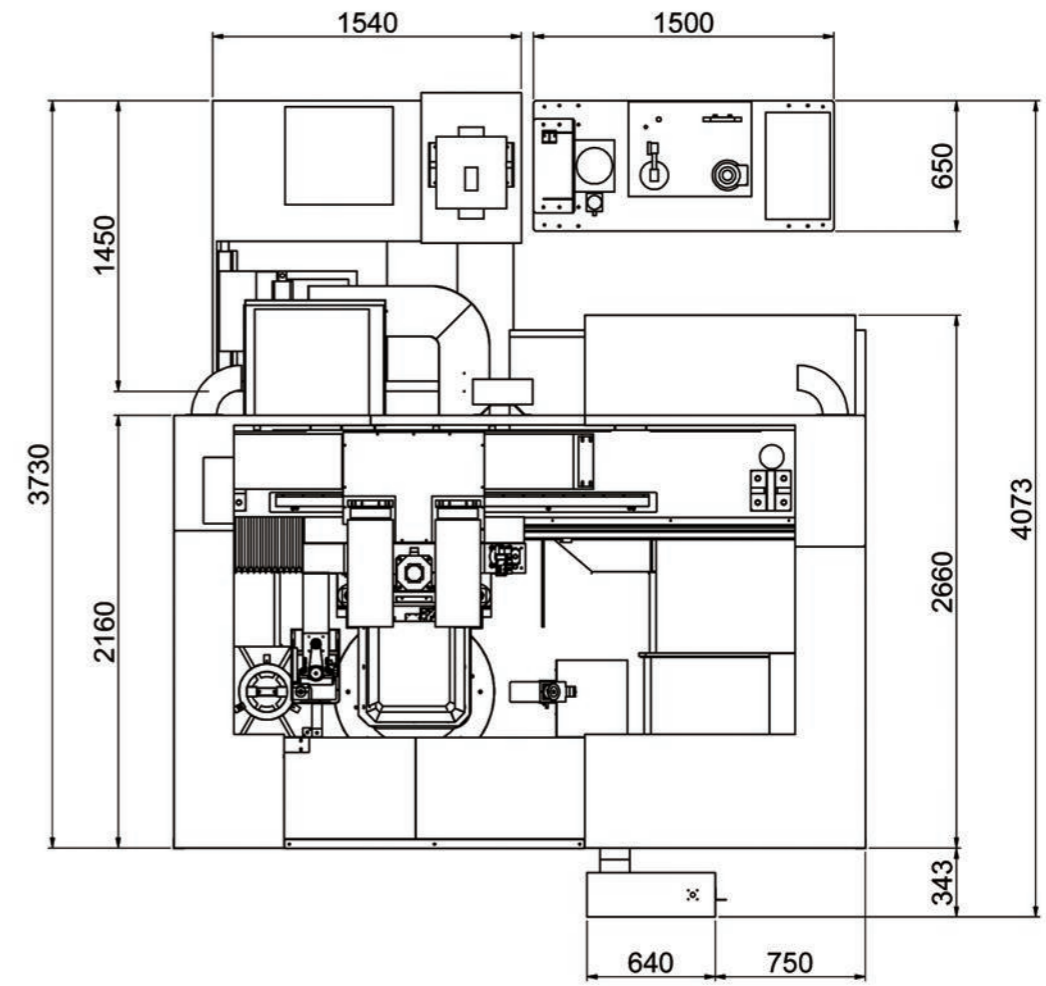

CVG-12CT外觀尺寸圖 External Dimension

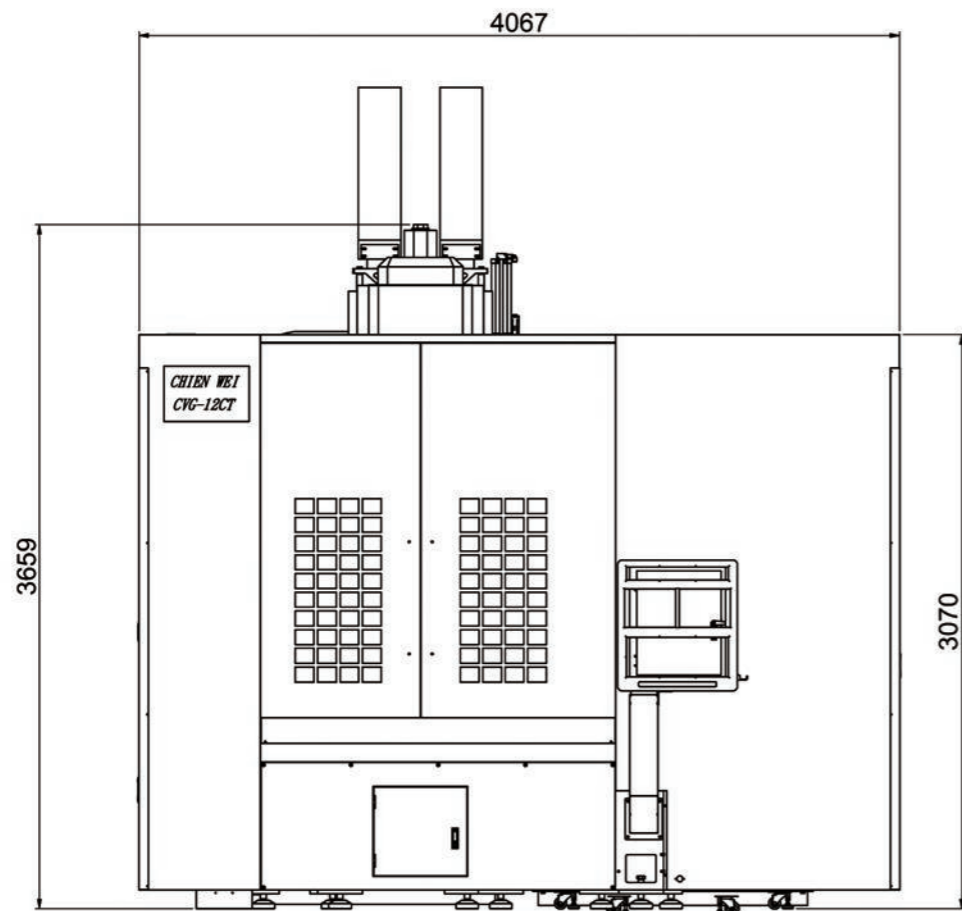
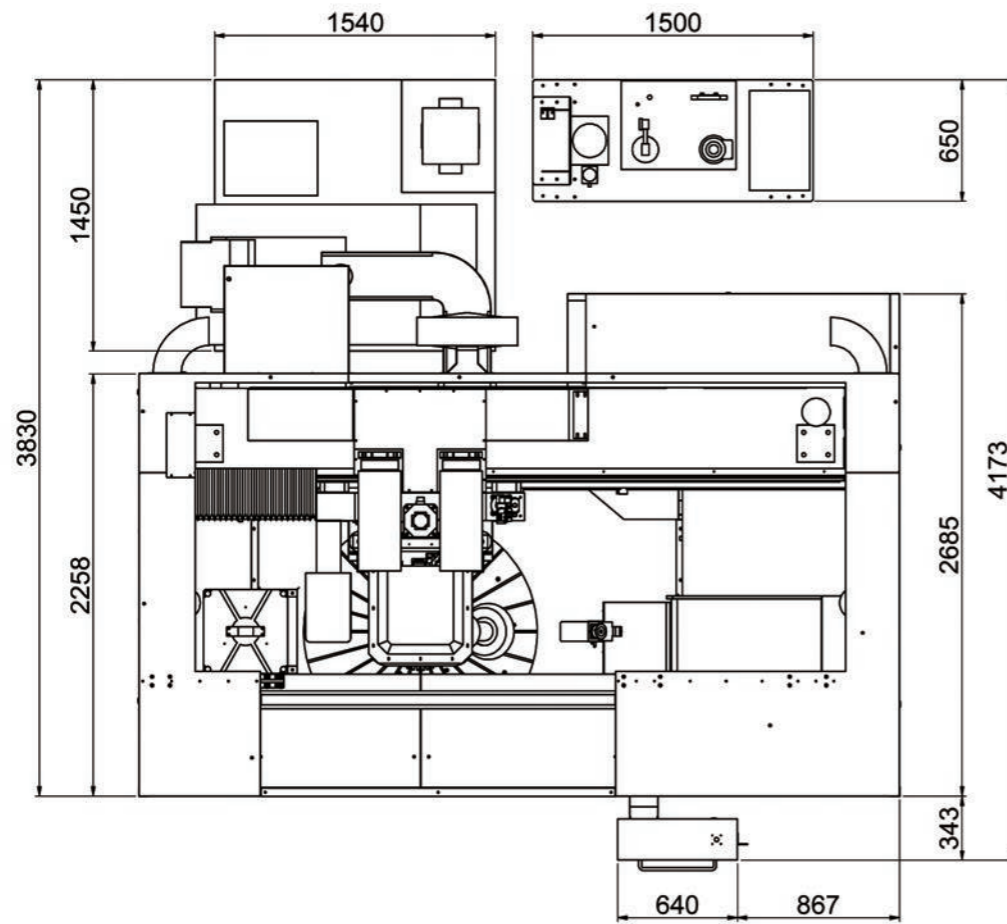

Standard tools

HSK-A QUILL AND GRINDING WHEEL / HSK-A 刀桿與砂輪

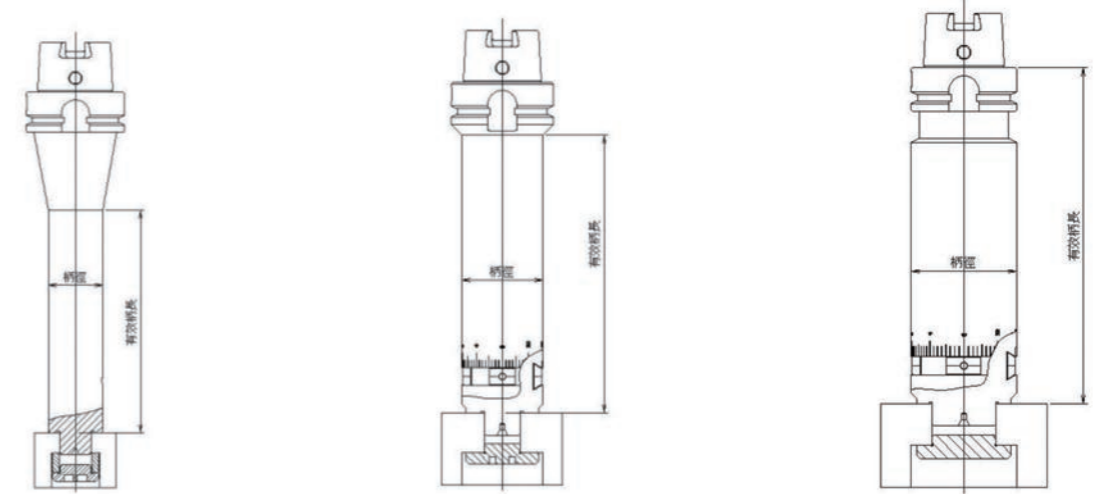

HSK-A 刀桿型式 I

HSK-A 刀桿型式 II

HSK-A 刀桿型式 III

CVG - 4T (HSK-A 63)				
刀桿型式	柄 徑	有效長度	砂輪直徑厚度	可研磨最小孔徑與深度
I	φ 35	144	φ 52 X 35X φ 20	φ 62 X 164
II	φ 50	172	φ 75 X 45 X φ 22.23	φ 85 X 202
III	φ 63	190	φ 150 X 60X φ 50.8	φ 160 X 235
III	φ 63	200	φ 100 X 50X φ 38.1	φ 110 X 235

CVG-8CT / 12CT (HSK-A 100)				
刀桿型式	柄 徑	有效長度	砂輪直徑與厚度	可研磨最小孔徑與深度
I	φ 55	230	φ 100 X 50X φ 38.1	φ 110 X 265
II	φ 75	250	φ 125 X 50X φ 38.1	φ 135 X 285
III	φ 100	220	φ 200 X 65X φ 101.6	φ 210 X 270
III	φ 100	285	φ 250 X 60X φ 101.6	φ 260 X 330

GRINDING WHEEL / 砂 輪

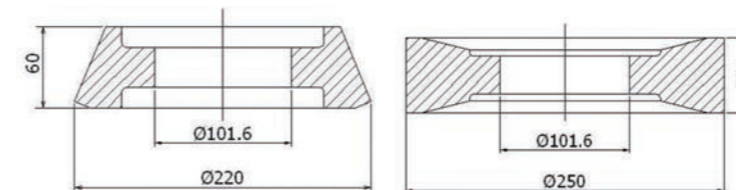

Workpiece Material 工件材質	SPEC. 規 格
QUENCHING 淬火	5KG
CAST 鑄鐵	GC80K