

Eumach

Always Step Ahead



VERTICAL MACHINE CENTER
立式綜合加工機

VMC-1100

專業CNC機械製造廠

A PROFESSIONAL CNC MACHINES MANUFACTURER

***The most rigid & compact box ways vertical
not only has box way machine's heavy cutting
but also those linear way machine's***



■ VMC-1100 with BT#40 spindle, 24 arm ATC, Mitsubishi M70 control.



■ BT#40 / 8000RPM (or up to 15000RPM)
belt drive, BT#40 / 8000轉或可達 15000轉



■ CAM type tool changer system
24/32 Tools刀臂式刀庫

***machining center with extreme performance,
capability – up to 26KW / #50 taper / gear head,
rapid feed – up to 36 meter per minute.***



- BT#50 6000RPM (optional up to 10000RPM)
Cartridge type spindle incorporated P4 high precision angular contact bearings ensures the maximum rigidity and highest accuracy.



- BT # 50 6000 轉主軸（或選配 10000轉）
砲彈式主軸方便維修，採用精密P4級主軸斜角滾珠軸承，確保主軸最大剛性及精度。



- VMC-1100 with BT#50 spindle, 24 arm ATC, Siemens 828D-SL control.

RIGID MEEHANITE CASTING FRAMES WITHOUT DEFORMATION

高剛性、高扭力的機身設計， 最佳的動態水平

- Z-axis Moving Balance By Air Cylinder Without Counter Weight, No Vibration, No Noise.
- Z-axis Servo Motor With Brake Unit To Protect The Head Down While Power Off On Short Time.
- Special Base Design Possibly Separate Lube-oil And Chip Water To Reduce The Water Pollution.
- More Than 5500kg Casting Frame And Total Machine Weight Up To 7300kg All Ensures Rigidity During Heavy Cutting And Stability In 24~36, Meter Rapid Feed.

- Z軸採用氣壓式配重平衡，可消除因配重所產生的震盪與聲響。
- Z軸伺服馬達加裝剎車裝置，多一層保護。
- 有油水分離的設計可將油與切削液大部份分離，以減少污臭並延長切削液使用壽命。
- 超過5500公斤鑄件床身及總重7300公斤機台重量，確保機台在重切削時的剛性以及每分鐘24~36米快速位移的穩定性。



- 4 Box-way Base & table Moving Full Support on 1100mm Travelled.
- 4硬軌設計工作台全行程支撐達到最佳的動態水平。

THE MACHINE QUALITY GUARANTEE

我們的品質保證



■ **LASER INSPECTED**
雷射檢驗



■ **BALLBAR TEST**
循圓測試



■ **SPINDLE VIBRATION TEST**
主軸震動測試

Carousel type magazine (standard)

斗笠式刀庫 (標準配備)

- The machine is equipped with a 20-tool carousel-type magazine which features fast tool change in only six seconds (tool to tool) and 12 seconds (chip to chip).
- 本機標準配備20支斗笠式刀庫，快速換刀時間為6秒（刀對刀）及12秒（換刀完成）



Chip Auger System (standard)

螺旋式切屑系統 (標準配備)

- Mounted at the front side of the machine, the chip auger system will deliver chips to a cart. It can be used together with the flushing nozzles to keep the machine clean at all times.
- 除屑螺桿安裝在機械前方，可將切屑輸送至集屑桶，並可搭配沖屑系統使用，隨時保持機械之清潔。



OPTIONAL ACCESSORIES (選購配備)



● Auto tool length measurement-2
自動刀長量測-2



● Chain type chip conveyor
履帶式排屑機



● Coolant thru tool holder
油路刀把

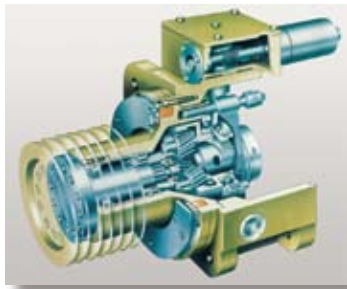

● Planetary gear box
行星式齒輪箱



● Oil skimmer
油水分離機



● Coolant thru spindle
主軸中心出水

拉桿螺栓、刀桿

PULL-STUD
TOOL SHANK(STD)
BT-40

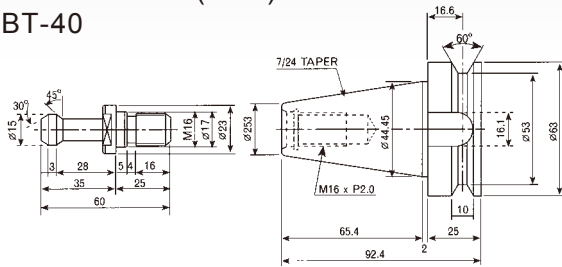

TOOL SHANK(OPT)
CAT-40/DIN69871

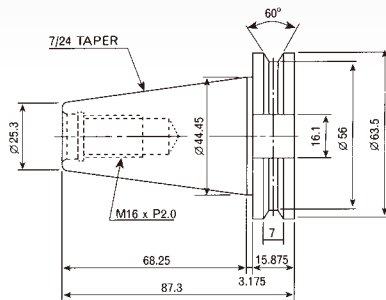

DIMENSIONS 機械外型尺寸

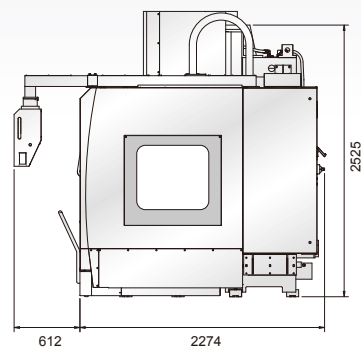
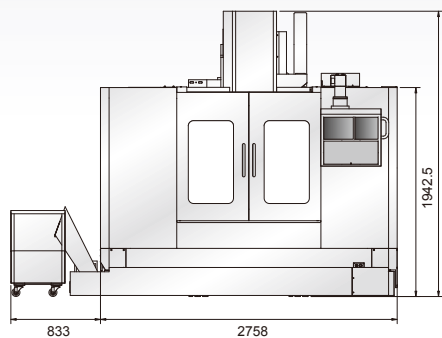

SPECIFICATIONS 機械規格

MODEL 型號		UNIT	VMC-1100	
SPINDLE 主軸	Taper	錐度	BT#	#40 #50
	Speed	轉速	RPM	8000 (~15000) 6000 (~10000)
	Front bearing diameter	軸承直徑	MM	70 90
	Motor	馬達功率	KW	7.5/11(~22/26)
TABLE 工作臺	Overall size	尺寸	MM	1270 x 640
	T slots (size×No×pitch)	T形槽	MM	18 x 5 x 125
	Maximum loading	最大荷重	KG	1200
TRAVEL 行程	X / Y / Z axis	三軸行程	MM	1100/610/610
	X/Y/Z slide way number	滑道數量	PCS	2/4/2
DISTANCES 相關距離	Spindle to column way	主軸至立柱	MM	660
	Spindle to table top	主軸至工作臺	MM	100 ~ 710 110 ~ 720
	Floor to table top	工作臺至地面	MM	895
AXIS MOTORS 軸向馬達	X/Y/Z axis	三軸扭力	Nm	12/22/12
	X/Y/Z motor power	三軸功率	KW	3/4/3
	Z axis balance design Z	Z軸配重方式		PNEUMATIC氣動
	Cutting federate	切削速率	MM / MIN	1-5000(~10000)
	Rapid federate	快速進給	M / MIN	24/24/24 (~36/36/30)
ATC 刀庫	Type	型式	TYPE	CAROUSEL ARM
	No. of ATC	刀具數量		20(~32) 24
	Max. tool dia./ length	最大刀徑/長	MM	106 / 300 125 / 300
	Max. tool weight	最大刀重	KG	7 15
	Tool to tool	刀具到刀具	SEC.	6 5
	Chip to chip	工件到工件	SEC.	12 10
BALLSCREWS 滾珠螺桿	Dia. ×pitch (X&Y axis)	直徑節距	MM×MM	40 × 12
	Dia. ×pitch (Z axis)	直徑節距	MM×MM	40 × 12
	Precision class (C3)	精密等級	MM/300MM	0.008
COOLANT & LUBRICATION 冷卻及潤滑	Coolant motor power	冷卻馬達功率	KW	0.86
	Coolant tank volume	冷卻水箱容量	L	200
	Coolant motor capacity	馬達效率	L / MIN	20
	Lubrication motor power	潤滑馬達功率	WATT	25
	Lubrication tank volume	潤滑油容量	L	2
ACCURACY 精度	Positioning	定位	MM	VDI 3441 : P 0.015MM
	Repeatability	重複	MM	VDI 3441 : PS0.01MM
	Roundness	真圓度	MM	JIS6338 : ±0.01MM / 300MM DIA.
MISCELLANEOUS	Net weight	機器淨重	KG	7300 8500
	Power required	所需電力	KVA	25
	Pneumatic required	所需空壓	KG / CM2	7

Note: () OPTION 括號內為選配

Cnc Controls Available 控制器可選擇



FANUC 發那科
Oi-MC / 31i-MB



HEIDENHAIN 海德漢
TNC-i530



MITSUBISHI 三菱
M70 / M720



SIEMENS 西門子
840D / 828D



EUMACH FAMILIES



◦ **VMC-2150**
Vertical machine center
400MM ~ 3200MM X axis travel



◦ **TVMC-2000 / 3000**
Moving column machine center
2320MM & 3320MM X axis travel



◦ **LBM-1500**
High speed bridge type machine center
1100MM ~ 2200MM X axis travel



◦ **FBM SERIES**
Floor type boring machining center



◦ **EBM-2150**
5 Face machine center
1400MM ~ 3200MM X axis travel



◦ **MB-1500**
Moving column horizontal machine center
1100MM ~ 2200MM X axis travel



◦ **DVM-4025**
2200mm ~ 6200MM X axis travel
double column machine center



◦ **FBE-1500**
Universal milling machine
1500MM ~ 5000MM X axis travel



◦ **UMC-1000**
5 axis machine center
1000MM x 800MM x 700MM travel

Eumach Co.,LTD.

★ Specifications subject to change without notice.
Catalogue No. A2070307

2, YING LIN LANE, HE-SHENG STREET, SHI-GANG DISTRICT, TAICHUNG CITY 422, TAIWAN, R.O.C.
TEL:886-4-25810031 FAX:886-4-25810003
<http://www.eumach.com>
E-mail:eumach.coltd@msa.hinet.net ; eumach@ms8.hinet.net

