

# Eumach

*Always Step Ahead*



**UMC-1600**

EMC / CE / ISO CERTIFIED

**5 AXES**

**A PROFESSIONAL CNC MACHINES MANUFACTURER**

# ***THE MOST EFFICIENT & INTELLIGENT MACH PERFORMANCE MACHINING, INCREASE PRO***

## **• UMC-1600 5 AXES SIMULTANEOUS MILLING CENTER:**

- Latest innovation of combination of both bridge type machine and traveling column type machine design advantage
- large 1620mm x 1260mm x 1050mm three linear axis travel
- $\phi 1320$ mm CNC continuous rotary table with 4000kg load
- $0.001^\circ$  swivel milling head with torque motor driven
- Standard 3 axis linear scales & 2 axis absolute rotary encoder
- Powerful motor spindle HSK-A100 / 37.4KW&54KW / 170Nm&390Nm / 8000RPM with  $\phi 100$ mm ceramic bearings
- Patented X axis 4 slide ways design (M417981 ) with maximum rigidity to ensure heavy cutting



# ***INING CONCEPT FOR MULTI-SIDED HIGH DUCTIVITY, FLEXIBILITY AND REPEATABILITY***



Sliding front & side doors with a super wide top opening, this make very easily for straight forward loading awkward shaped workpiece.

# NEXT GENERATION



## ● BALL SCREWS

- ▶ The high precise & rigid  $\Phi 55/55/63$ mm diameter ballscrews on 3 axes, driven by powerful AC servo motors, directly coupled by couplings provides the utmost results in high speed cutting for the very fine accuracy and finishing.

## ● ROLLER GUIDEWAYS

- ▶ The high rigid & heavy duty 55mm roller type linear motion guideways on 3 axes to provide low starting inertia, low friction and high acceleration, rates optimizing servo drive and ensure machine response immediately & precisely for high speed cutting requirements, especially in rapid positioning and contouring cutting.

# TECHNOLOGY DESIGN

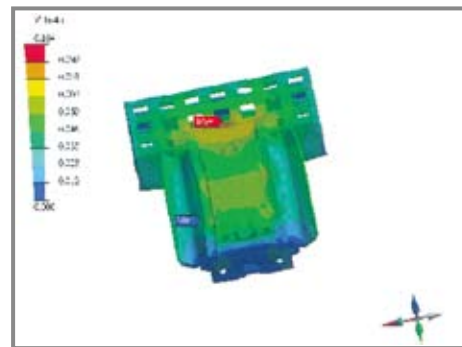
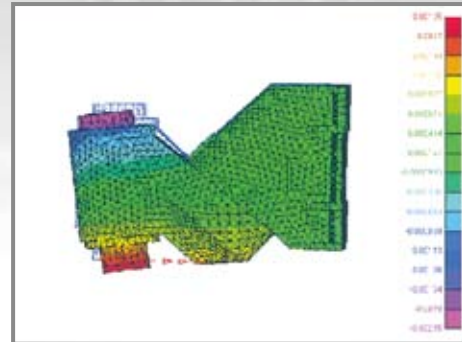
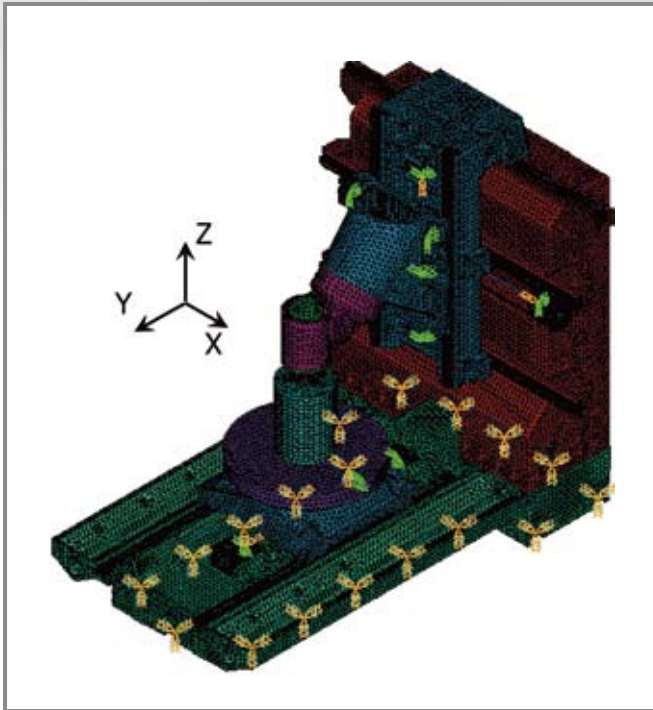

## ● RIGID CASTING FRAME

- ▶ Using the most advanced Computer Aided Design and Finite Element Method analysis programs, an extremely rigid casting frame is being created.

Swiss Schneegerber made 55mm width roller guideways :

- Z axis - 2 guideways with 6 runner blocks

- X axis - 4 guideways with 8 runner blocks

- Y axis - 2 guideways with 4 runner blocks

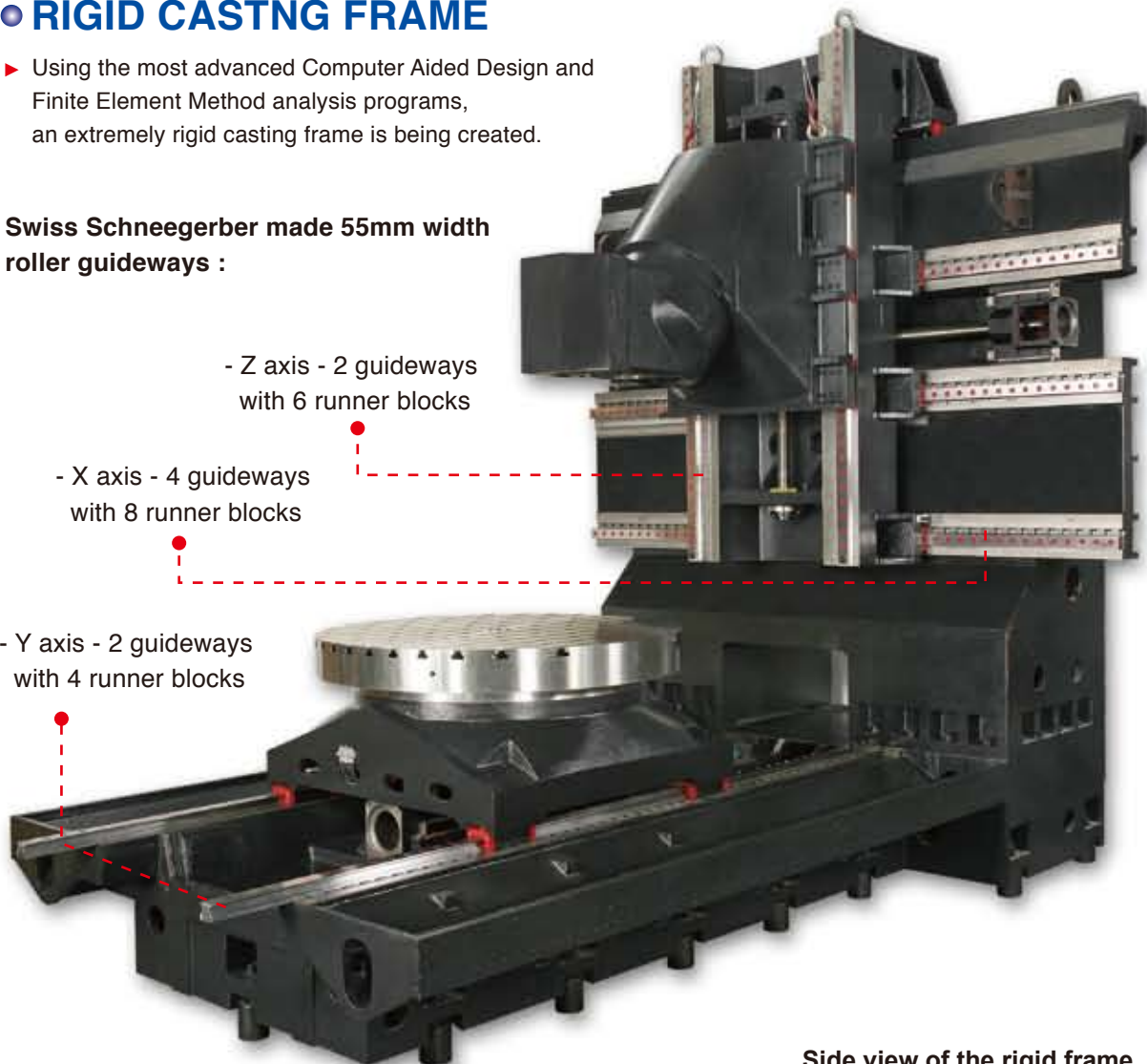

Side view of the rigid frame

# B AXIS INNOVATIVE SWIVEL MILLING HEAD



- ▶ The latest technology torque motor manages the B axis continuous swivel milling head , it guarantees maximum movement dynamic and linearity and thanks to the absence of those traditional mechanical kinematics parts, it results a much higher performance on finishing surface. The direct reading system by a high precision angular encoder is being integrated for maximum precision.



- ▶ As a controlled B-axis, the swivel head changes from vertical to horizontal machining in seconds.



- ▶ Offers an extra flexibility; the fully automatic 0.001 indexing from vertical to horizontal positions by means of torque motor, this gives operator an extra flexibility: multi-sided machining without re-setting the workpiece; manufacture of complex components with a single set-up; 5 sided machining without additional fixture.

# C AXIS DURABLE CNC ROTARY TABLE



## ● STANDARD:

- ▶  $\phi 1300\text{mm}$  dimension with 4000kg load driven by AC servo motor, it can be indexing  $0.001^\circ$  by high precision worm gear, positioning by hydraulic cylinder; a high precision rotary encoder is included.

## ● OPTIONAL:

- ▶ 1320mm diameter torque motor drive rotary table with maximum rotation 30 RPM, 3940Nm peak torque, 10000Nm brake torque, 4000kg load,  $\pm 5'' / \pm 2.5''$  positioning / repeatability accuracy, German made !

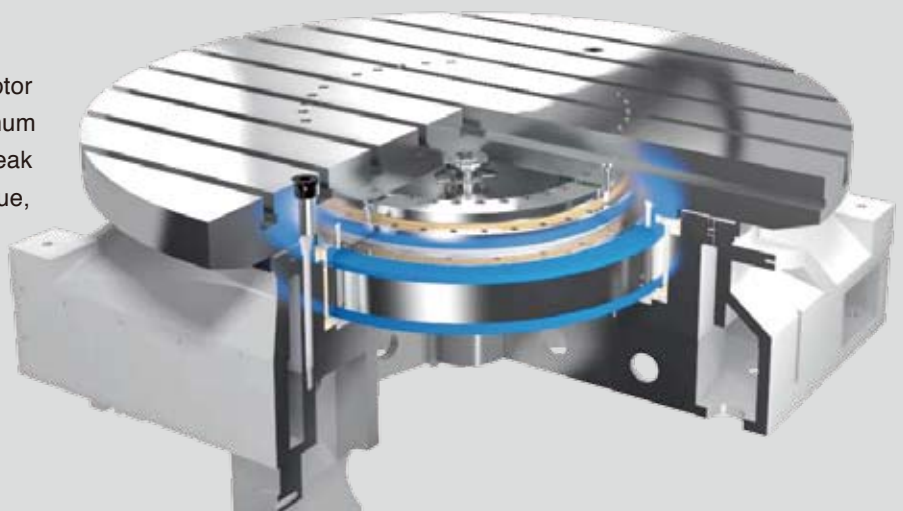

# AUTOMATIC TOOL CHANGER



Standard 60 stations automatic tool changer with maximum 150mm diameter / 350mm length / 20 KG tool.

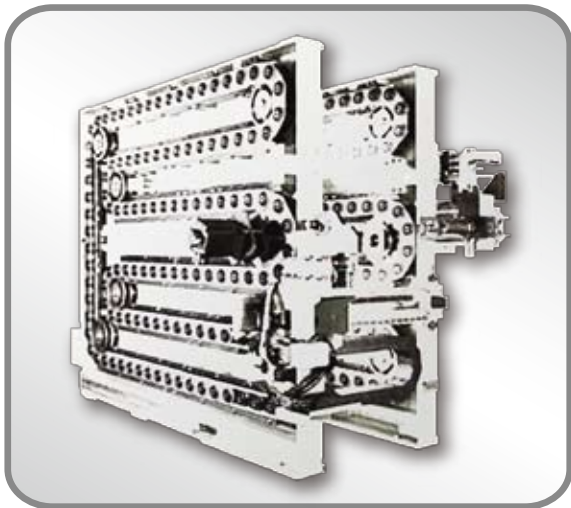

Automatic tool changer is possible to increase up to 90, 120, 150, 180 tool stations as option

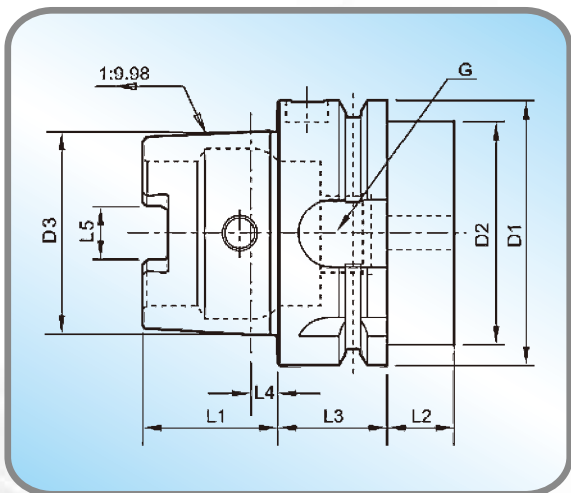

HSK-A100 tool holder

Length	D1	D2	D3	L1	L2	L3	L4
HSK-A100	100	88	75.013	50	16	29	10

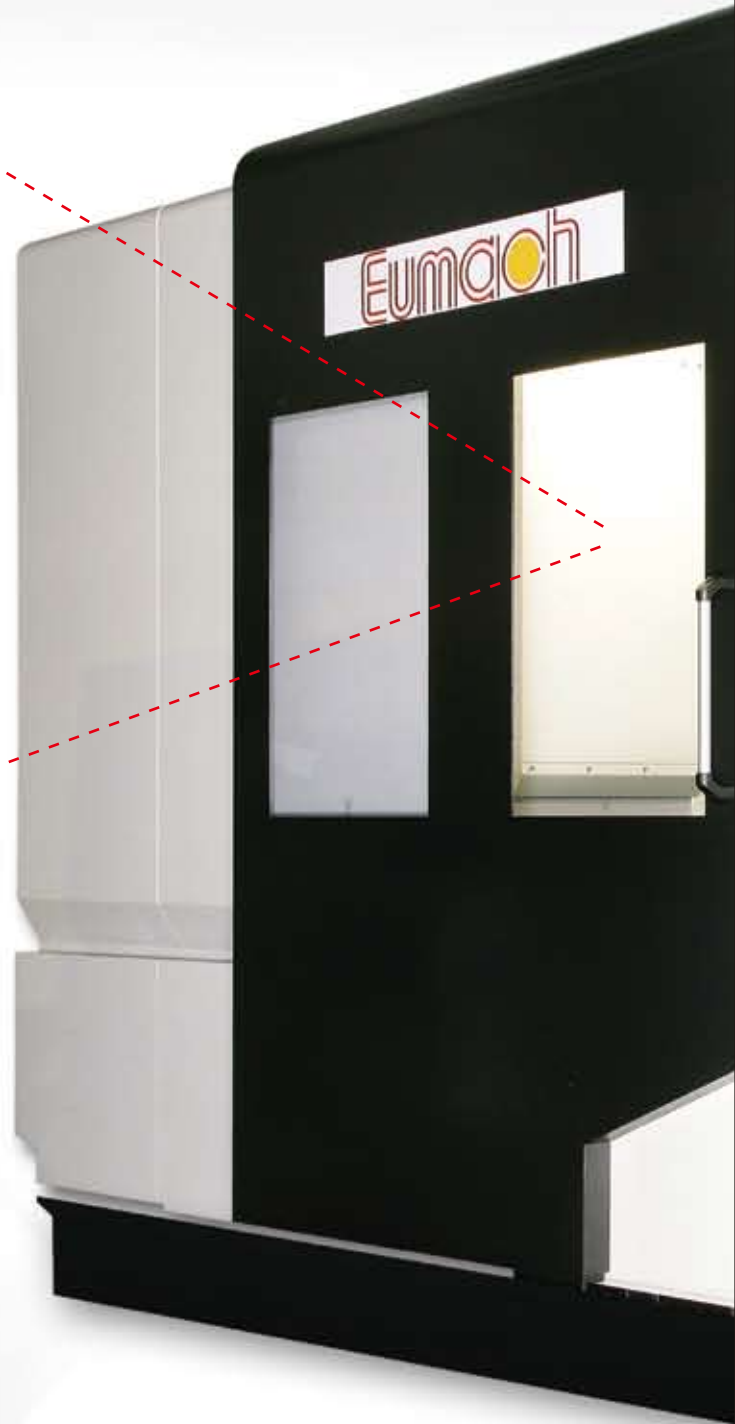



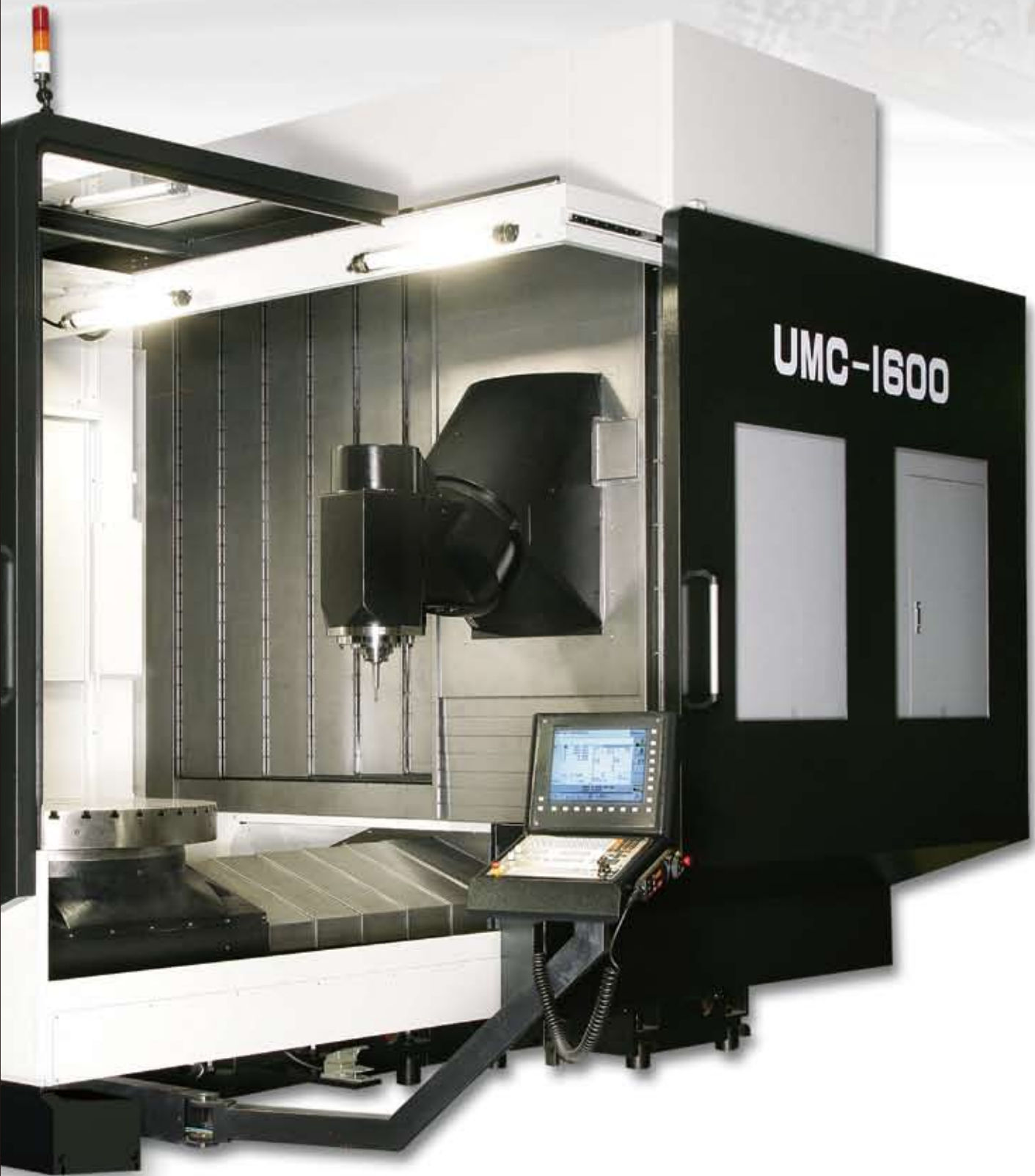

• TWIN SLIDING DOORS OPEN 90 °

L5	G
20.02	M24x1.5

# POWERFUL MOTOR SPINDLES



**N320 standard**

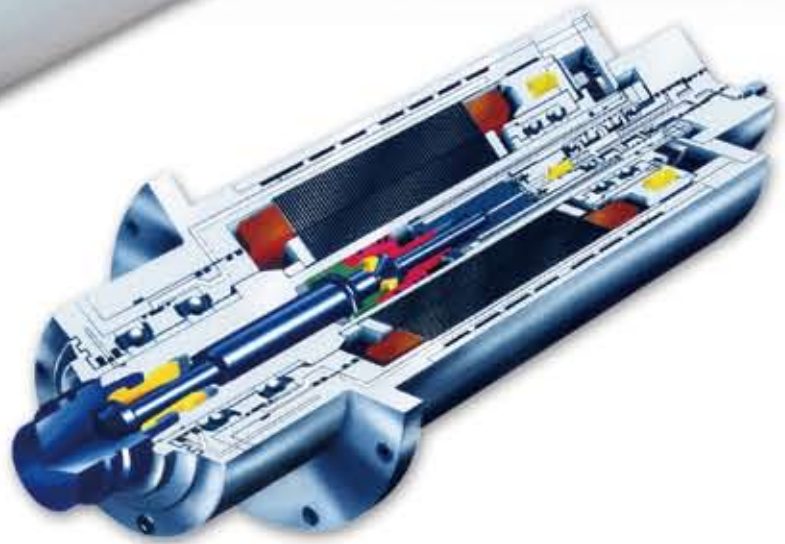

**C42-238 optional**



**P320 optional**

Models	N320	C42-238	P320
Max. speed - RPM	8000	7000	800
Rated speed - RPM	1500	1000	1000
Spindle taper	HSK-A100		
Housing diameter - MM	320	238	320
Power S1/S6 - KW	37.4 / 54	42 / 52	36 / 45
Torque S1/S6 - Nm	170 / 390	400 / 525	340 / 428
Bearings diameter - MM	100	100	110
Coolant thru spindle	OPT	OPT	OPT
Air thru spindle	N / A	OPT	OPT

# DIGITAL CNC CONTROL

- FULLY ENCLOSED  
SPLASH GUARD



## Heidenhain iTNC-530 HSCI newest control :

1. MC 6222 1.8GHz more powerful CPU than before
2. 32G SSDR storage media resistance to vibration
3. New HEROS 5 operating interface with PDF viewer
4. TE 630 key board & MB 620 panel & 15" XGA screen



## Siemens 840Di Solution Line newest control :

1. NCU 730.2 with PLC 317 - 2DP + 40GB HD
2. PCU 50.3 1.5Ghz , 512Mb, WinXP/Pro interface
3. Shopmill + 3D simulation 1 & HMI Advanced
4. MCP483C panel + OP 015A 15" TFT screen

# RELATED DISTANCES

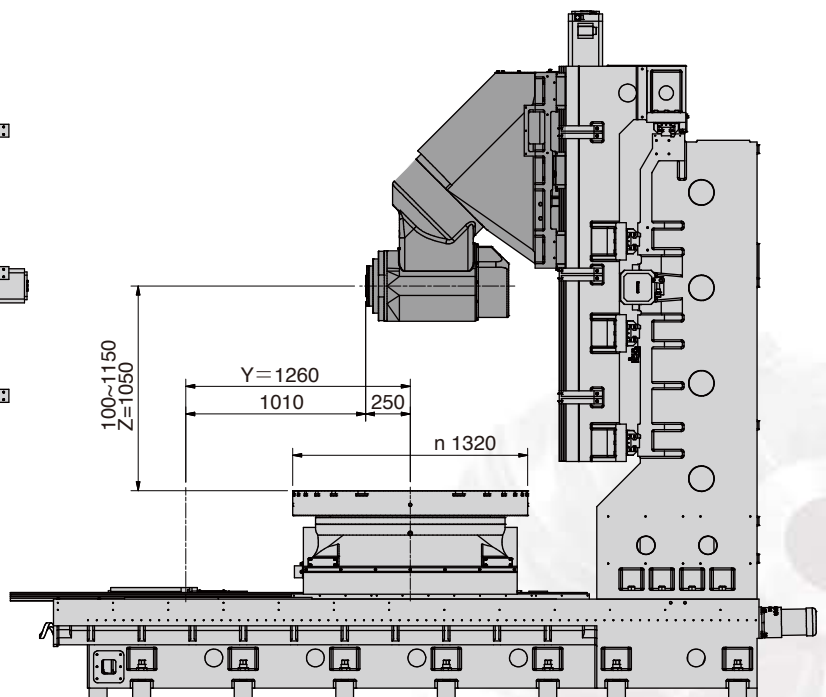
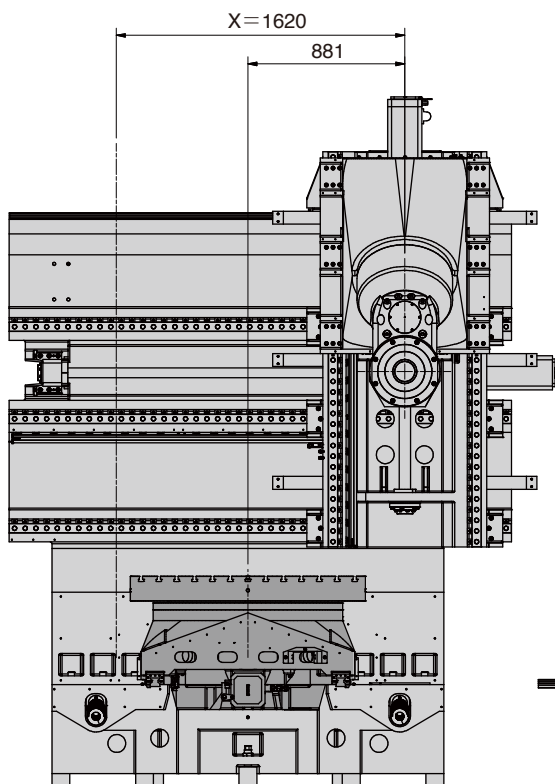
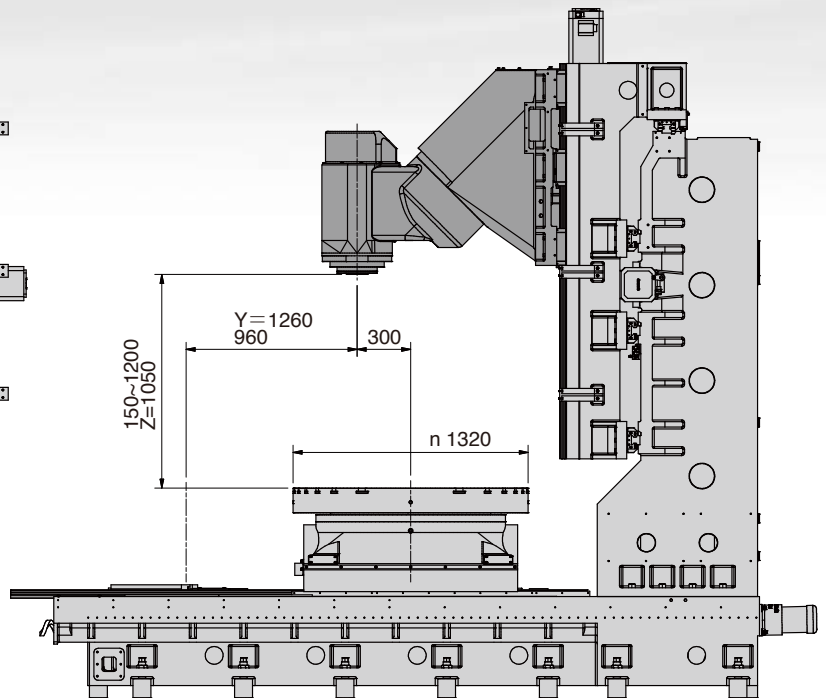
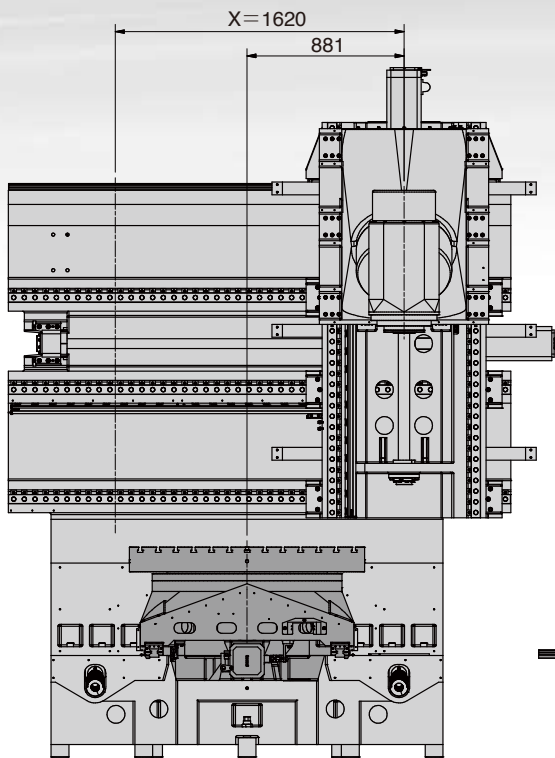

# MACHINE DIMENSION

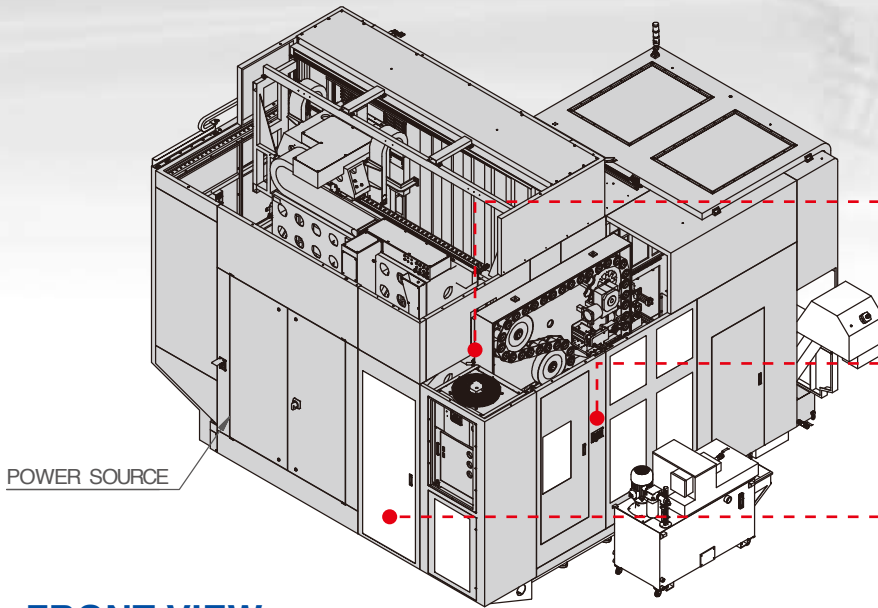

- ▶ hydraulics, spindle water cooler all in machine back for easy maintenance with safety door
- ▶ manual tool loading from automatic tool changer magazine side door with transparent window
- ▶ centrally arranged for all solenoids, pneumatics and lubrication device in one area

## 1. FRONT VIEW

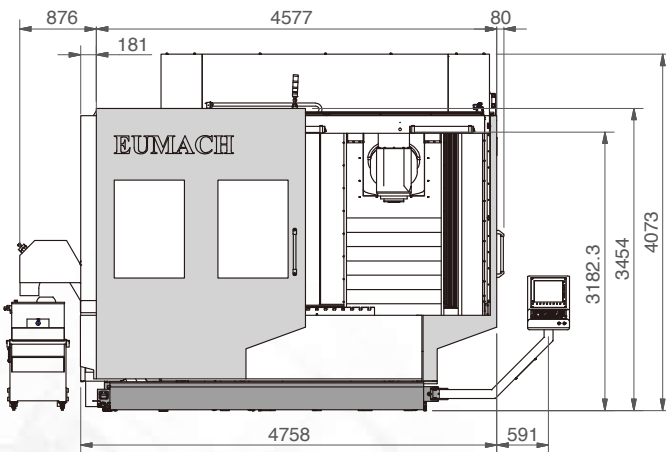

## 2. SIDE VIEW

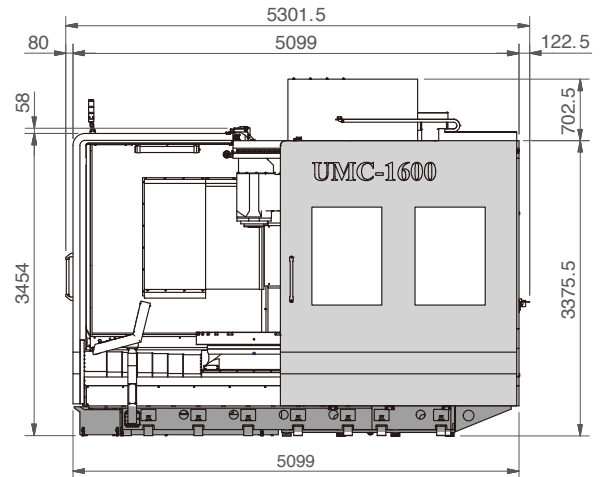

## 3. TOP VIEW

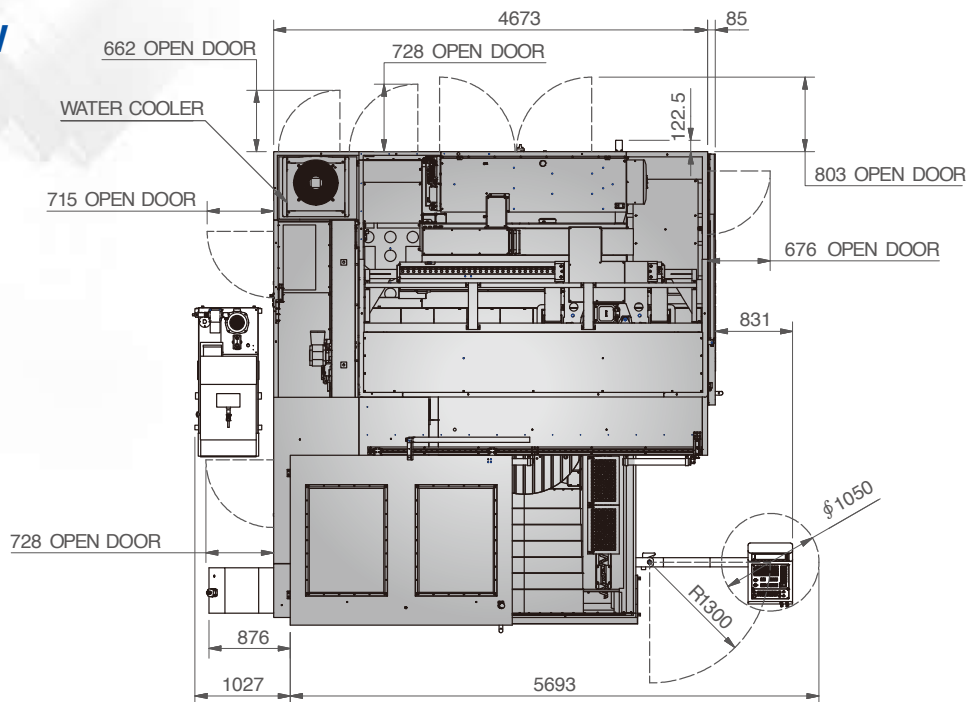

Note : Above dimension is standard and will be different if with different options !

# APPLICATIONS

► The milling center can be used not only the typical various turbo impeller industries but also servicing aerospace aviation, automotive and mould industries etc.

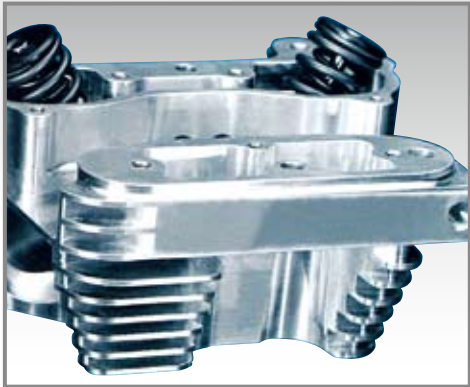

**1.** CYLINDER

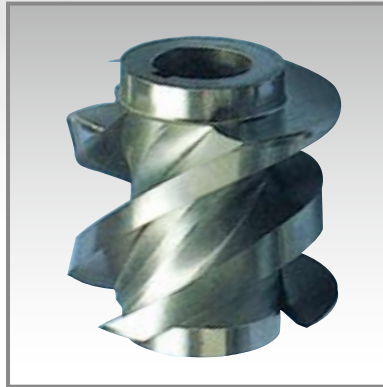

**2.** SHAFT

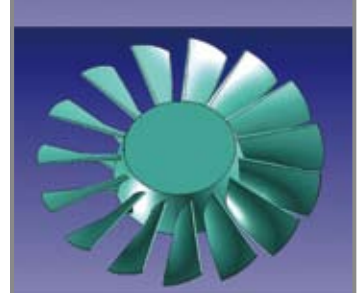

**3.** MOULD



**4.** WHEEL



**6.** TURBO IMPELLERS



10-BLADES



16-BLADES

# MACHINE SPECIFICATIONS

<b>Travel</b>	X / Y / Z axis	1620mm / 1260mm / 1050mm
<b>Swivel head (B axis)</b>	Vertical to horizontal time	3seconds
	Transmission	DD torque motor
	Rotary angle	+10° / -190°
<b>Motor spindle</b>	Maximum spindle speed	8,000 RPM
	Spindle power S1 / S6	37.4 KW / 54 KW
	Spindle torque S1 / S6	170 Nm / 390 Nm
	Spindle taper	HSK-A100 / BT / CAT / SK#50
	Front bearing diameter	100mm
<b>Distances</b>	V : spindle nose to table top	150mm ~ 1200mm
	H : spindle center to table top	100mm ~ 1150mm
	V : spindle nose to table center	-300mm ~ 960mm
	H : spindle center to table center	-250mm ~ 1010mm
	Spindle center to column	1105mm
<b>Rotary table (C axis)</b>	Table dimension	φ 1320mm
	Table to floor	1085mm
	Maximum loading	4000KG
	Maximum rotation	30 RPM
	Transmission	DD torque motor
	Indexing increment	0.001°
	T slots	13x18HxP100
<b>Ball screw</b>	X / Y / Z Diameter x pitch	φ 55/ 55/63mm x 16/12/12mm
<b>X / Y / Z axis Roller guide</b>	Number x width	4/2/2 slide ways x 55mm
	Runner blocks number	8/4/6
<b>Feed rate</b>	Rapid feed X / Y / Z	24/24/24m/min
	Cutting feed	20/20/20 m/min
<b>A T C</b>	Tools number	60 pieces
	Maximum tool diameter	φ 150mm
	Maximum tool length	350mm
	Maximum tool weight	20 kgs
	Tools exchanging position	horizontal
<b>Weight</b>	Before packing	32000KG
<b>CNC</b>	Brands	Heidenhain & Siemens

## STANDARD FEATURES & ACCESSORIES

1. FULL SPLASH GUARD WITH TOP ROOF
2. PROGRAMMABLE COOLANT SYSTEM
3. AUTOMATIC LUBRICATION SYSTEM
4. SPINDLE AIR BLAST SYSTEM
5. WORK ALARM, INDICATON LAMPS
6. SPINDLE WATER COOLER
7. LEVELLING BOLTS & PADS
8. RS-232 TERMINAL INTERFACE PORT
9. MACHINE & CONTROL MANUALS
10. TOOLBOX WITH SPANNERS & WRENCHES
11. CHAIN TYPE CHIP CONVEYORS + 2 SCRCW CHIP AUGERS
12. 3 AXIS LINEAR SCALES + 2 AXIS ROTARY ENCODERS

## OPTIONAL ACCESSORIES :



TOOL PROBE



TOOL LASER MEASUREMENT



WORK PLECE PROBE



COOLANT THUR SPINDLE DEVICE



# EUMACH FAMILIES



• **VMC-2150**  
Vertical machine center  
400MM ~ 3200MM X axis travel



• **TVMC-2000 / 3000**  
Moving column machine center  
2320MM & 3320MM X axis travel



• **LBM-1500**  
High speed bridge type machine center  
1100MM ~ 2200MM X axis travel



• **FBM SERIES**  
Floor type boring machining center



• **EBM-2150**  
5 Face machine center  
1400MM ~ 3200MM X axis travel



• **MB-1500**  
Moving column horizontal machine center  
1100MM ~ 2200MM X axis travel



• **DVM-4025**  
2200mm ~ 6200MM X axis travel  
double column machine center



• **FBE-1500**  
Universal milling machine  
1500MM ~ 5000MM X axis travel



• **UMC-1000**  
5 axis machine center  
1000MM x 800MM x 700MM travel

**Eumach Co.,LTD.**

★ Specifications subject to change without notice.  
Catalogue No. A2030102

2, YING LIN LANE, HE-SHENG STREET, SHI-GANG DISTRICT, TAICHUNG CITY 422, TAIWAN, R.O.C.  
TEL:886-4-25810031 FAX:886-4-25810003  
<http://www.eumach.com>  
E-mail:[eumach.coltd@msa.hinet.net](mailto:eumach.coltd@msa.hinet.net) ; [eumach@ms8.hinet.net](mailto:eumach@ms8.hinet.net)

