

TPAK Series

Coolant Pump



WALRUS
WALRUS PUMP CO., LTD.

TPAK Series Coolant Pump



Power: ¼ - 1.5 HP

50Hz

Head: Up to 12M

Flow: Up to 360 L/min

60Hz

Head: Up to 17M

Flow: Up to 400 L/min

Outlet: ½" - 1½"

Applications

The TPAK Series coolant pump is design for the circulation and spraying of cooling lubricants, especially for machine tools.

This series may use on all machine tools performing Turning, Milling, Drilling, Cutting, Slitting, Grinding etc. operation.

It is suitable to carry liquids such as water, coolant, light oil and other clean, non aggressive matters.

Operating Conditions:

1. Ambient temperature :Max. +40°C
2. Liquid temperature range:+0°C ~ +90°C
3. Operating pressure:Max. 10 kg/cm²

Pump Construction

The pump is one-chamber vertical centrifugal pump, co-axial pump/motor design, impellers mounted on extended motor shaft.

Model code

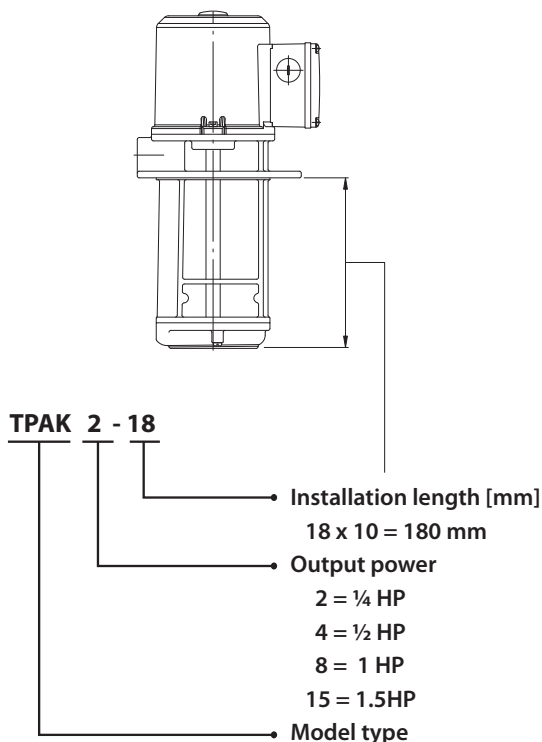

Motor

Enclosure protection class: IP54

Insulation class: F.

Frequency range: 50 / 60 Hz

Nominal speed : 2900 / 3500 rpm

Standard voltages : 3Ø 50Hz: 200-255V / 380-440V

3Ø 60Hz: 200-255V / 380-480V

Installation

Maximum liquid level

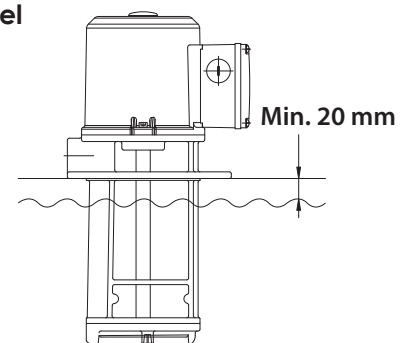

Performance curve

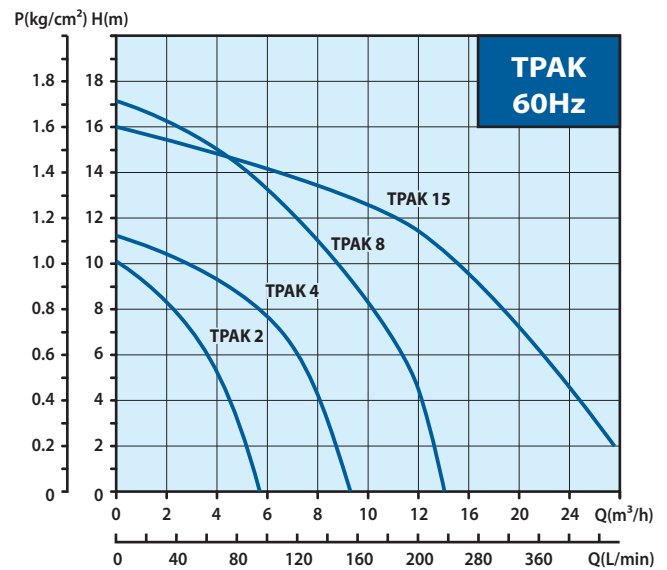
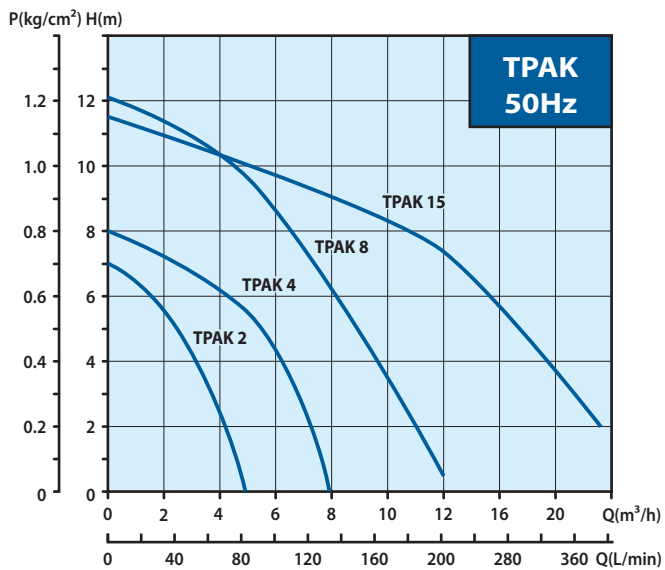

Dimensions (mm)

Model	DIMENSIONS (mm)											N.W.(kg)	
	A	B	C	D	E	F	G	H	I	J	K		
TPAK 2-15	325	150	175	24	Rp 1/2"	80	113	Ø120	Ø120	160	4xØ8 PCD158	9.5	36
TPAK 2-18	355	180	175	24	Rp 1/2"	80	113	Ø120	Ø120	160	4xØ8 PCD158	10.0	36
TPAK 2-25	425	250	175	24	Rp 1/2"	80	113	Ø120	Ø120	160	4xØ8 PCD158	10.6	24
TPAK 4-15	386	150	236	28	Rp 3/4"	85	111	Ø135	Ø135	170	4xØ9 PCD170	11.2	24
TPAK 4-18	416	180	236	28	Rp 3/4"	85	111	Ø135	Ø135	170	4xØ9 PCD170	11.9	24
TPAK 4-25	486	250	236	28	Rp 3/4"	85	111	Ø135	Ø135	170	4xØ9 PCD170	12.7	24
TPAK 8-18	457	180	277	29	Rp 1"	95	111	Ø150	Ø150	190	4xØ9 PCD185	15.5	24
TPAK 8-25	527	250	277	29	Rp 1"	95	111	Ø150	Ø150	190	4xØ9 PCD185	17.1	24
TPAK 15-25	573.5	250	323.5	40	Rp 1 1/2"	122	124	Ø180	Ø180	200	4xØ9 PCD210	24.0	15

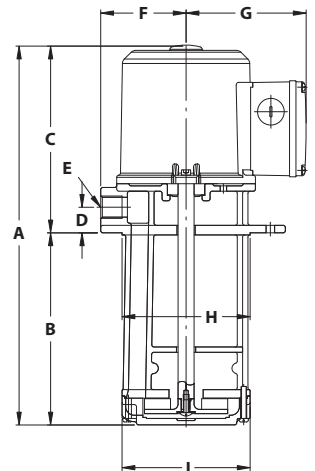

Electrical data, 50/60Hz

Model	PH (Ø)	Cycle (Hz)	Input Power (W)	Volts (V)	Full load current (A)
TPAK 2	3	50	270	200-255 / 380-440	1.0-1.3 / 0.6-0.8
		60	350	200-255 / 380-480	1.2 / 0.7
TPAK 4	3	50	440	200-255 / 380-440	1.5-1.9 / 0.9-1.2
		60	620	200-255 / 380-480	2.0 / 1.1
TPAK 8	3	50	930	200-255 / 380-440	3.1-4.4 / 1.9-2.6
		60	1320	200-255 / 380-480	4.0 / 2.4
TPAK 15	3	50	1300	220 / 380	4.8 / 2.8
		60	2000	220 / 380	5.4 / 3.1

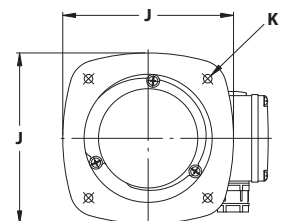



WALRUS
www.walruspump.com